

EE65 Series

Air Velocity Transmitter for HVAC Applications

EE65 air velocity transmitters are ideal for accurate ventilation control applications. They are operating on an innovative hot film anemometer principle. The E+E thin film sensor guarantees very good accuracy at low air velocity, which is not possible for conventional anemometers with commercial temperature sensors or NTC bead thermistors. Moreover, the E+E sensor is much more insensitive to dust and dirt than all other anemometer principles. This means high reliability and low maintenance costs.

EE65 series are available with current or voltage output, the measuring range and the response time can be selected with jumpers by the user.

Low angular dependence enables easy, cost-effective installation. An integrated LCD display and a version with remote sensing probe are available.



EE65 - A / B



EE65 - C

Typical Applications

HVAC
process and environmental control

low angular dependence
easy installation
adjustable to application requirements

Features

Technical Data

Measuring values

Working range ¹⁾	0 ... 10 m/s (0 ... 1,960 ft/min)	
	0 ... 15 m/s (0 ... 2,940 ft/min)	
	0 ... 20 m/s (0 ... 3,920 ft/min)	
Output ¹⁾	0 - 10 V	-1 mA < I _L < 1 mA
	4 - 20 mA	R _L < 450 Ω
Accuracy at 20 degC, 45 % RH and 1013 hPa	0 ... 10 m/s (0 ... 1,960 ft/min)	± (0.3 m/s (60 ft/min) + 3 % of measuring value)
	0 ... 15 m/s (0 ... 2,940 ft/min)	± (0.3 m/s (60 ft/min) + 3 % of measuring value)
	0 ... 20 m/s (0 ... 3,920 ft/min)	± (0.3 m/s (60 ft/min) + 4 % of measuring value)
Response time τ ₉₀ ^{1) 2)}	typ. 2 sec. or typ. 0.2 sec.	

General

Power supply	SELV 24 VAC/DC ± 10 %
Current consumption for AC supply	max. 150 mA
for DC supply	max. 90 mA
Angular dependence	< 3 % of measurement at Δα < 10°
Electrical connection	screw terminals max. 1.5 mm ²
Electromagnetic compatibility	EN 50081-1
	EN 50082-1 EN 50082-2
Housing/protecting class	Polycarbonat / IP65 (NEMA 4) , with LC-display IP40



¹⁾ Selectable by jumper

²⁾ Response time τ₉₀ is measured from the beginning of a step change of air velocity to the moment of reaching 90% of the step.

Temperature range	working temperature probe	-25 ... +50 degC (-13 ... + 122°F)
	working temperature electronic	-10 ... +50 degC (+14 ... + 122°F)
	storage temperature	-30 ... +60 degC (-22 ... + 140°F)

Dimensions (mm) 1" = 25 mm

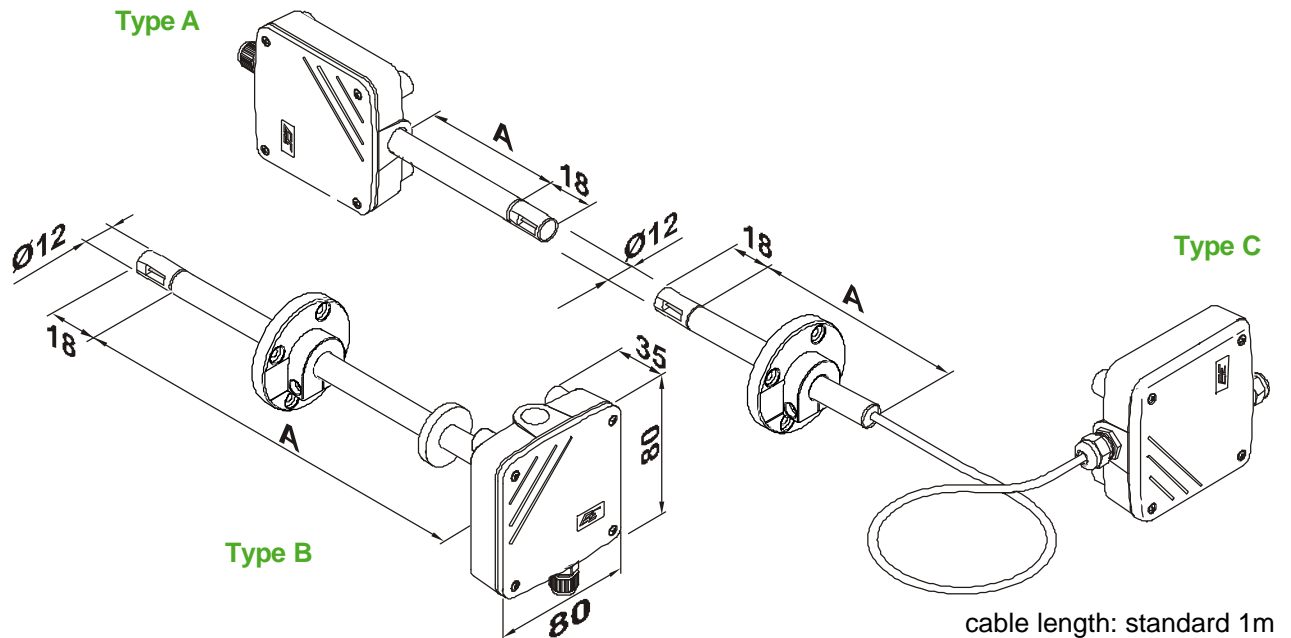

Connection Diagram

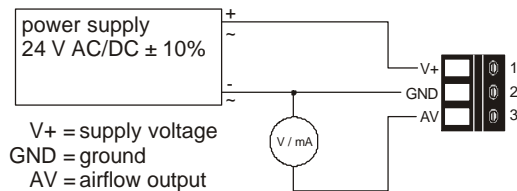

Ordering Guide

MODEL	HOUSING	PROBE LENGTH (according to "A")	CABLE LENGTH (only Type C)	DISPLAY
velocity (V)	wall mounting (A)	100 mm (3)	1 m (no code)	without display (no code)
	duct mounting (B)	200 mm (5)	2 m (K200)	with display (D02)
	seperated sensor probe (C)	others (x)	5 m (K500) 10 m (K1000)	
EE65-				

Order Example

EE65-VB5-D02

model: velocity
housing: duct mounting
probe length: 200 mm
display: with LC-display